

# SK-50

## FLOATING BALL STEAM TRAP

### GENERAL FEATURES

Ayvaz SK-50 Steam Trap carry out continuous evacuation with varying amount of condensate at steam saturation temperature. It is not affected by sudden and wide pressure changes. It is preferable for systems where condensate discharge is requested to be rapid and it is preferred where condensate accumulation is inconvenient. Ideal for automatic temperature controlled systems.

In addition to the float performs the discharge task, the air is carried out by the thermostatic capsule in the body. In this way, the impact of the water hammer in the pipeline are prevented. At the same time, if the float loses its function for any reason, thermostatic capsule is activated and continues to drain the condensate and prevents congestion in the system.

#### Material Parts

**Body (DN25):** GGG 40 Ductile Iron

**Body (DN32-40-50):** GG 25 Cast Iron

**Inner Parts:** AISI304 Stainless Steel

#### Connection:

Threaded or Flanged

#### Nominal Diameter:

DN25 (1") – DN50 (2")

#### Pressure:

Max. 16 bar

#### Working Temperature:

Max. 250 °C

#### Application Areas:

- Heat exchangers
- Heating batteries
- Tanks
- Drying rollers

#### Installation:

It should be in a horizontal position that allows the float in the steam trap to work vertically.

Connection Type	Flanged	Threaded
Diameters (mm)	25-32-40-50	1" - 1 1/4" - 1 1/2" - 2"
Weight (kg)	8.3-20.8-21.8-33	6.8-16.8-17.6-22

# SK-50 FLOATING BALL STEAM TRAP

## DN25 TECHNICAL SPECIFICATIONS

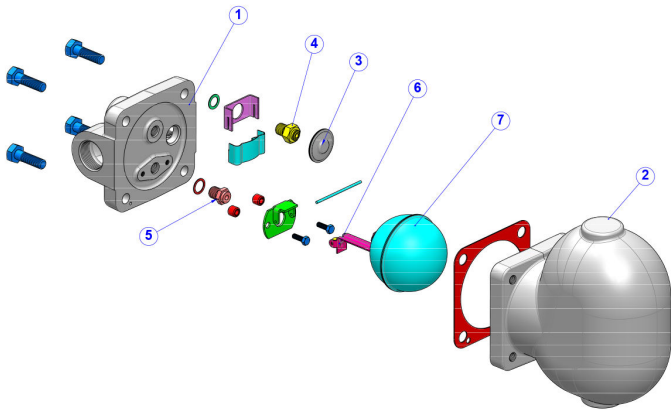

Discharge Capacities  
(1")

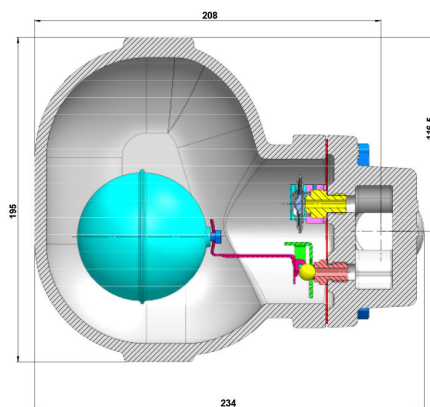
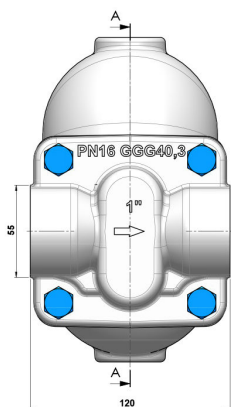
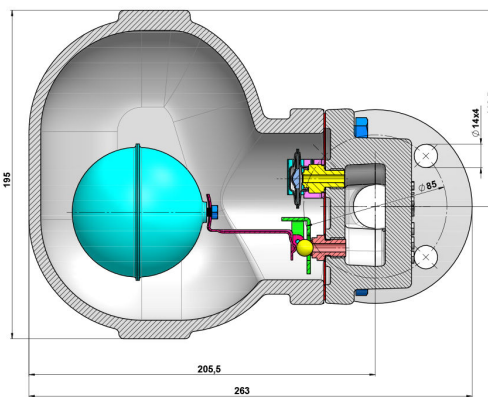
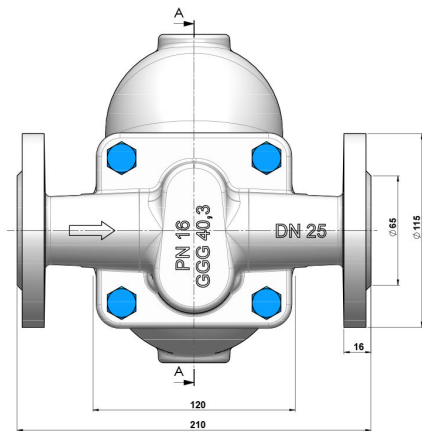
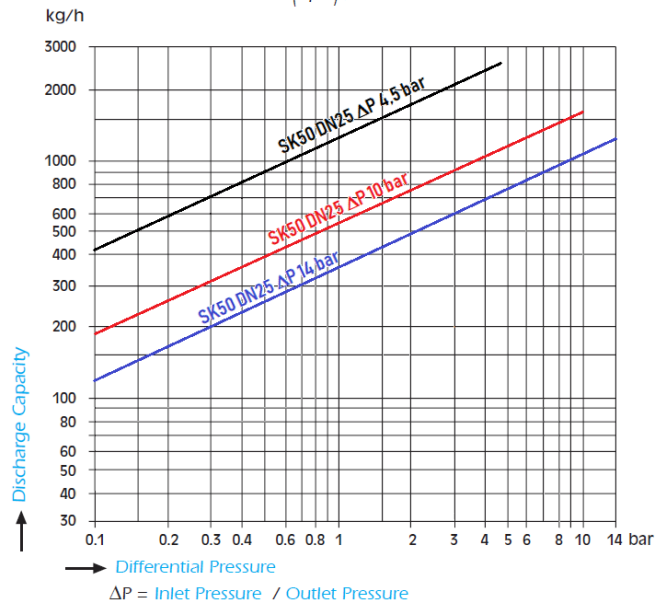

SPARE PARTS		
No	PART NAME	MATERIAL
1	Body	GGG 40
2	Cover	GGG 40
3	Thermostatic Capsule	Stainless Steel
4	Capsule Seat	Stainless Steel
5	Float Seat	Stainless Steel
6	Float Lever	Stainless Steel
7	Float	Stainless Steel

All dimensions are given in mm.

# SK-50 FLOATING BALL STEAM TRAP

## DN32-40-50 TECHNICAL SPECIFICATIONS

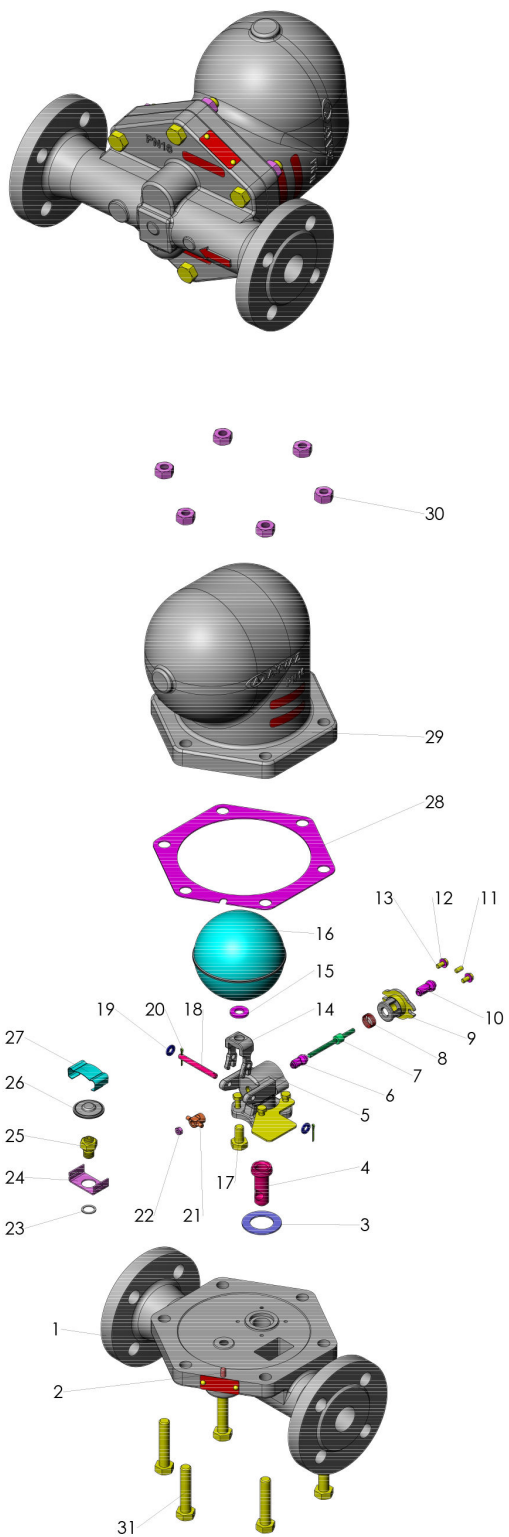

### Discharge Capacities

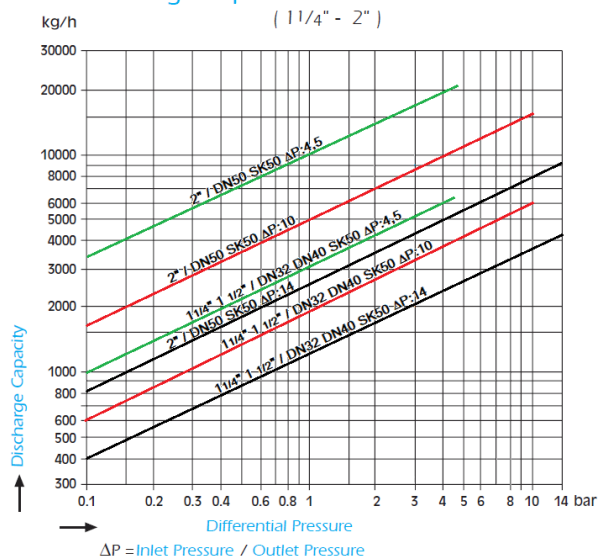

SPARE PARTS		
No	PART NAME	MATERIAL
1	Body	GG-25 Cast Iron
2	Spring Sleeve	55 Si 7
3	Bear Gasket	%94 Pure Graphite
4	Erosion Prevention	AISI 304 SS
5	Bear	AISI 430 SS
6	Valve	AISI 430 SS
7	Bear Shaft	AISI 304 SS
8	Spring	AISI 302 SS
9	Bear Cover	1.4581
10	Valve	AISI 430 SS
11	Stay Screw	A2-70
12	Washer	AISI 304 SS
13	A.K.B. Screw	A2-70
14	Salıncak	AISI 304 SS
15	Washer	AISI 304 SS
16	Float	AISI 316 SS
17	A.K.B. Screw	A2-70
18	Float Connection Shaft	AISI 304 SS
19	Washer	AISI 304 SS
20	Pim	AISI 304 SS
21	Pulley Wheel	AISI 304 SS
22	Nut	A2
23	Seat Gasket	AISI 304 SS
24	Thermostatic Element Lower Part	AISI 304 SS
25	Thermostatic Ele. Seat	AISI 304 SS
26	Thermostatic Element	
27	Thermostatic Element Upper Part	Spring Steel
28	Cover Gasket	%94 Pure Graphite
29	Cover	GG-25 Cast Iron
30	Nut	8.8
31	A.K.B. Screw	8.8

# SK-50 FLOATING BALL STEAM TRAP

## DN32-40-50 TECHNICAL SPECIFICATIONS

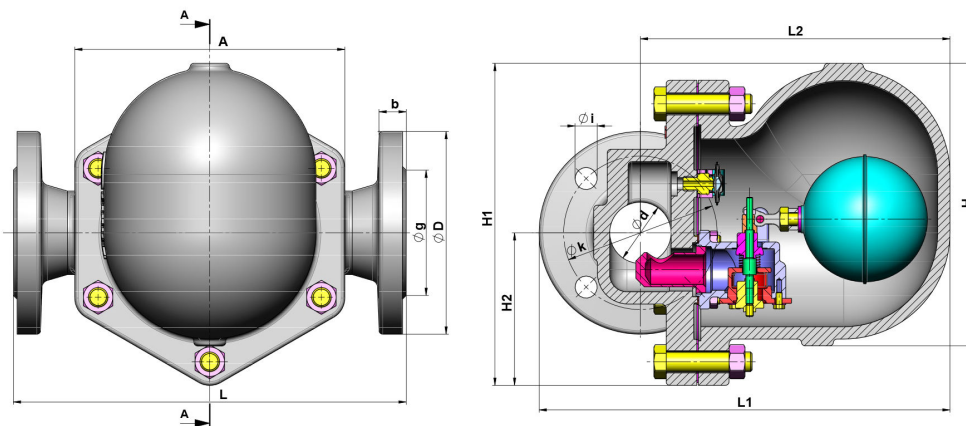

SIZE	∅ D	∅ k	∅ g	b	∅ lxn	A	H1	H2	H	L1	L2	L
DN32	140	100	78	20	18x4	190	237.5	107.5	207	277	245	320
DN40	150	110	88	20	18x4	190	237.5	107.5	207	277	245	320
DN50	160	125	102	22	18x4	220	262	124	230	290	252	320

All dimensions are given in mm.

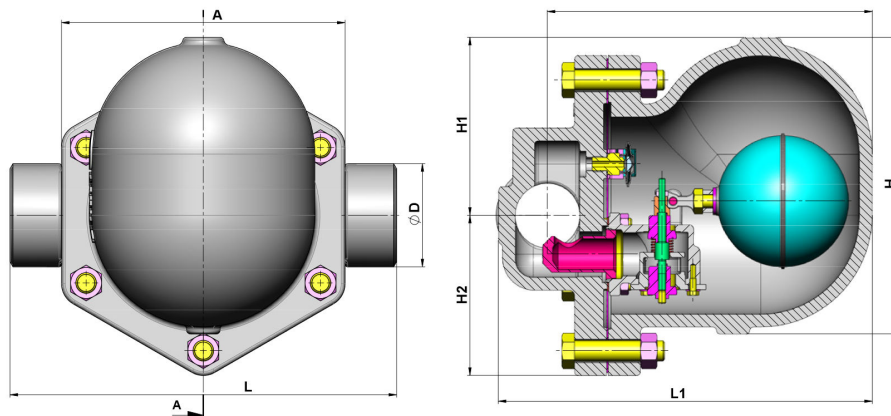

SIZE	∅ D	A	H	H1	H2	L1	L2	L
1 1/4"	70	190	207	207	237.5	107.5	277	270
1 1/2"	70	190	207	207	237.5	107.5	277	270
2"	80	220	220	230	230	124	290	300



### HEAD OFFICE - FACTORY

Atatürk Sanayi Bölgesi Hadımköy Mahallesi Mustafa İnan Caddesi No: 44 Arnavutköy - İSTANBUL  
 Tel: +90 212 771 01 45 (pbx) | Fax: +90 212 771 47 27  
 info@ayvaz.com | www.ayvaz.com

**Cona**  
**Caserta/Italy**  
 Tel: +39 0823 187 3988  
 rmolaro@ayvaz.com

**Ayvaz Russia**  
**Moscow/Russia**  
 Tel: +7 9254070230  
 eakinci@ayvaz.com

**Ayvaz Germany**  
**Viernheim/Germany**  
 Tel: +49 62046014399  
 germany@ayvaz.com

**Ayvaz Ukraine**  
**Kiev/Ukraine**  
 Tel: +380 44 390 57 57  
 info@ayvaz.com.ua

**Tricorr**  
**Warsaw/Poland**  
 Tel: +48-32-783-295-1  
 tricorr@tricorr.eu

**Ayvaz Baku**  
**Baku/Azerbaijan**  
 Tel: +99(455) 579-84-32  
 ahayatov@ayvaz.com

**Haci Ayvaz M.E.**  
**Dubai/U.A.E**  
 Tel: +971 544431048  
 +971 501306871  
 mideast@ayvaz.com

**Ayvaz China**  
**Jinan/China**  
 Tel: +86 0574 5897 3851  
 info@ayvazchina.com

**Ayvaz Kazakhstan LLP**  
**Almaty/Kazakhstan**  
 Tel: +7 (727) 327 97 57  
 info\_kz@ayvaz.com  
 www.ayvaz.kz

**Ayvaz N**  
**Ispereh/Bulgaria**  
 Tel: +359 8431 27 32  
 office@ayvaz-n.eu

**Ayvaz Serbia**  
**Belgrade/Serbia**  
 Tel: +381 61 658 70 52  
 yakbiyik@ayvaz.com

**Ayvaz Vietnam**  
**HCMC/Vietnam**  
 ggursoy@ayvaz.com  
 Tel: +84 89 8508345

**Ayvaz Nigeria**  
**Lagos/Nigeria**  
 dige@ayvaz.com  
 Tel: +234 906 308 6617  
 Tel: +234 909 465 3877