

Direct action pressure reducing valve



For steam and gases. (For liquids, consult our technical department).

Suitable for application in; ironing machines, laundries and dry cleaners', cooking vats, textile machinery, drying cylinders, autoclaves, steam ovens, distilleries, heat exchangers, the food industry, chemical laboratories, etc.

Specifications

- Materials carefully selected for resistance to wear, extreme temperatures and corrosion. They can be fully recycled, and use a single, non-metallic, asbestos-free joint.
- Simplicity of design, ensuring minimum maintenance requirements.
- Easy installation; may be assembled in any position, even upside down.
- Moderate weight and size.
- Interior design conceived for maximum capacity and performance for size.
- Easy to adjust. The valves are supplied unregulated, but with the corresponding spring, duly identified, for the required pressure reduction.
- Rating plate which identifies the regulation field.
- Three springs, easily interchangeable and identified by colour and code.
- Anchoring system immune to vibrations; may be sealed to prevent manipulation.
- Self-centring lock, independent of axle, designed to guarantee absolute precision of regulation at the most demanding points.
- Protective filter for the locking surfaces.
- High degree of airtightness of the lock at zero consumption, exceeding the requirements of EN 12266-1.
- Stainless steel bellows welded to the plasma. Airtightness tested with helium, ensuring absolute reliability and long life.
- All valves undergo thorough testing.
- Each component is numbered, registered and inspected. If previously requested, the valve will be accompanied by certificates corresponding to materials, batch, tests and performance.

IMPORTANT

We recommend, if necessary, the use of thermal and acoustic insulation textile jackets Model 008.

Depending on demand:

- May be manufactured using other materials for specific working conditions (high temperatures, fluids, etc.).
- Other connections.
- Degreased and completely free of oils and greases.



EN ASME/ANSI

N°. PIECE	PIECE	MATERIAL
		CARBON STEEL
1	Body	Carbon steel (EN-1.0619) (1)
2	Seat	Stainless steel (EN-1.4028)
3	Seal	Plastic seal
4	Bottom cover	Nodular iron (EN-5.3105)
5/15	Body gasket	Graphite
6	Guide bush	Graphite PTFE (Teflon)
7	Conical spring	Stainless steel (EN-1.4310)
8/11	O-ring	Fluoroelastomer (Viton)
9	Guide	Stainless steel (EN-1.4028)
10	Washer	PTFE (Teflon)
12	Shutter	Stainless steel (EN-1.4028)
13	Flange	Carbon steel (EN-1.0460)
14	Filter	Stainless steel (EN-1.4301)
16	Spindle disc	Stainless steel (EN-1.4404)
17	Spindle	Stainless steel (EN-1.4404)
19	Bellows	Stainless steel (EN-1.4571)
20	Bellows ring	Stainless steel (EN-1.4404)
21	Cap	PTFE (Teflon)
22	Cover gasket	Graphite
23	Regulating bolt	Carbon steel (EN-1.1191)
24	Bellows disc	Stainless steel (EN-1.4404)
25	Bellows	Stainless steel (EN-1.4571)
26	Bellows ring	Stainless steel (EN-1.4404)
27	Spring	Chrome-silicon steel (EN-10270-2-FDSiCr)
28	Washer	Carbon steel (EN-1.1141)
29	Spring nut	Carbon steel (EN-1.1141)
30	Cover	Aluminium (EN-AC-44200)
31	Washer	Carbon steel (EN-1.1141)
32	Bolt	Carbon steel (EN-1.1191)
33	Sealing wire	Sealing wire
34	Handwheel	Aluminium (EN-AC-44200)
35	Washer	Carbon steel (EN-1.1141)
36	Interlocking pin	Carbon steel (EN-1.1141)
37	Plate features	Stainless steel (EN-1.4301)
38	Nut	Carbon steel (EN-1.1141)
39	Decorative cap	Carbon steel (EN-1.1141)
40	Ring Disc	Stainless steel (EN-1.4404)
41	Washer	Stainless steel (EN-1.4301)
DN		25 to 50 (EN, ANSI)
PN		16
OPERATING CONDITIONS	PRESSURE IN bar	16
	MAX. TEMP. IN °C	184
	MIN. TEMP. IN °C	-10

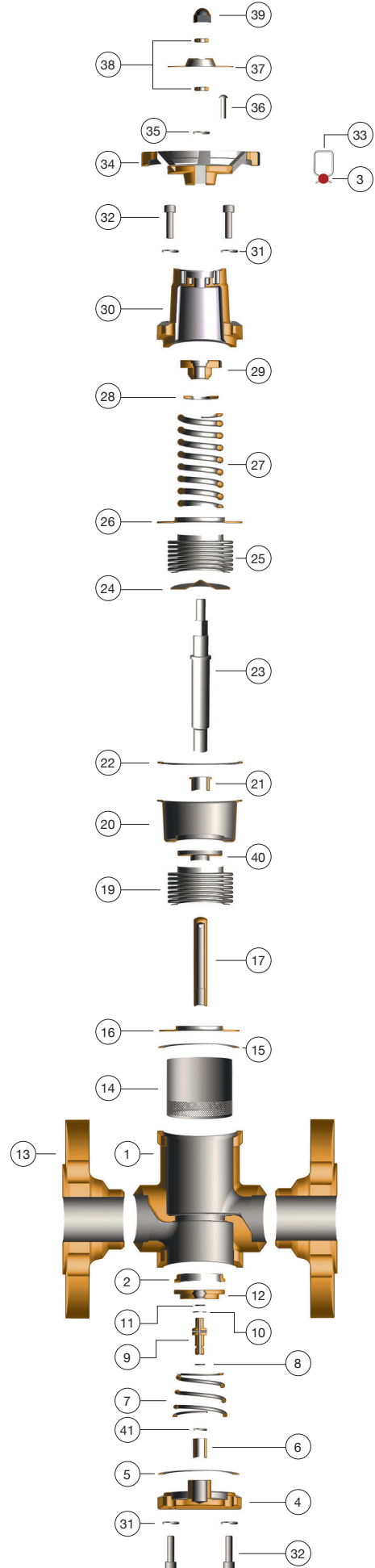

(1) DN-25 Nodular iron (EN-5.3105)

MODEL	614											
DN	25			32			40			50		
CONNECTIONS	I- Flanges PN-16 EN-1092-1 II- Flanges class 150lbs ASME/ANSI B.16.5											
	I		II		I		II		I		II	
H	57,5			57,5			57,5			57,5		
H1	171			171			171			171		
h	25			25			25			25		
L	160			180			200			230		
B	75			75			75			75		
D	115	110	140	115	150	125	165	150	115	125	165	150
K	85	79,4	100	88,9	110	98,4	125	120,7	85	79,4	100	88,9
l	14	15,9	18	15,9	18	15,9	18	19,1	14	15,9	18	19,1
b	17,7	17,7	18	15,9	18	17,5	18	19,1	17,7	17,7	18	19,1
DRILLS N°	4			4			4			4		
WEIGHT IN kgs.	7,24			9,27			9,84			9,46		
SPRING REGULATING RANGE IN bar (REDUCED PRESSURE)	0,14 to 1,70	1,40 to 4,00	3,50 to 8,60	0,14 to 1,70	1,40 to 4,00	3,50 to 8,60	0,14 to 1,70	1,40 to 4,00	3,50 to 8,60	0,14 to 1,70	1,40 to 4,00	3,50 to 8,60
CODE	NODULAR IRON 2001-	614.51061	614.51062	614.51063								
	CARBON STEEL 2001-				614.51441	614.51442	614.51443	614.51241	614.51242	614.51243	614.52041	614.52042

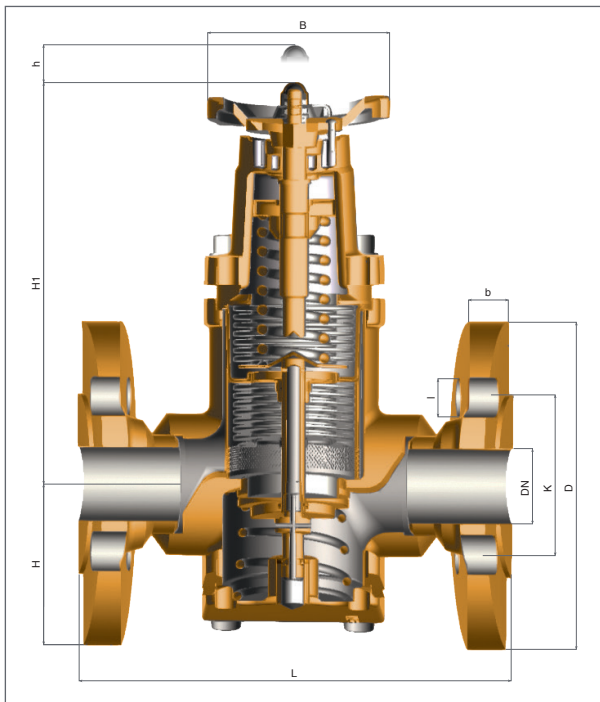
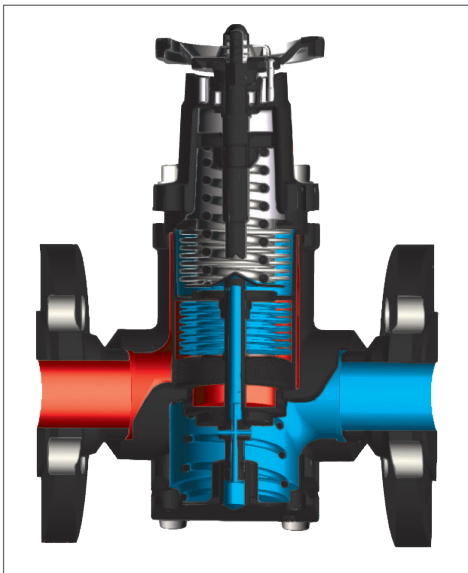

TABLE OF PRESSURES, FLOW COEFFICIENTS AND REGULATION FIELDS					
DN		25	32	40	50
MAXIMUM INPUT PRESSURE IN bar (P1 MAX.)		16			
MAXIMUM REDUCTION DIFFERENTIAL IN bar		P1:10			
MINIMUM REDUCED PRESSURE IN bar (P2 MIN.)		0,14			
FLOW COEFFICIENT Kvs m ³ /h ΔP = 1 bar		9,3	11,1	15,7	16,2
SPRING REGULATING RANGE IN bar (REDUCED PRESSURE)	0,14 to 1,70	CODE	56494		
		IDENTIFICATION COLOUR	White		
	1,40 to 4,00	CODE	56495		
		IDENTIFICATION COLOUR	Pink		
	3,50 to 8,60	CODE	56496		
		IDENTIFICATION COLOUR	Red		

FLOWS									
DN		25		32		40		50	
PRESSURE IN bar		I - Saturated steam in kg/h. II - Air at 0°C and 1,013 bar in [Nm ³ /h].							
INPUT P1	REDUCED P2	I	II	I	II	I	II	I	II
2	0,2	40	46	67	54	72	81	107	115
	1	105	119	175	141	190	212	280	302
	1,5	130	148	217	174	236	263	347	374
3	0,3	60	68	69	80	109	121	160	172
	1	120	137	137	161	218	243	320	345
	1,5	153	173	174	204	277	308	407	438
	2	175	199	200	234	318	354	467	503
	2,5	195	222	223	261	354	394	520	560
4	0,4	98	111	115	131	182	197	266	280
	1	145	165	167	194	264	293	387	417
	1,5	175	200	200	234	318	354	467	503
	2	205	233	229	274	372	415	547	589
	2,5	230	262	264	307	418	465	613	661
	3	245	279	282	328	445	495	653	704
5	0,5	115	131	192	154	209	233	306	330
	2	225	256	375	301	409	455	600	647
	3	268	304	466	358	486	541	713	769
	4	290	330	483	388	527	586	773	833
6	0,6	125	142	208	167	227	253	333	359
	2	252,5	287	421	338	459	511	673	726
	3	291	331	485	389	529	588	776	836
	4	320	364	533	428	582	647	853	919
	5	335	381	558	448	609	677	893	963
7	0,7	170	193	283	228	309	344	453	489
	2	265	301	442	355	482	536	707	762
	3	313	355	521	418	568	632	833	898
	4	343	390	571	458	623	692	913	984
	6	373	424	621	498	677	753	993	1070
8	0,8	190	216	317	254	345	384	507	546
	2	280	319	467	375	509	566	747	805
	3	335	381	558	448	609	677	893	963
	4	370	421	617	495	673	748	987	1063
	6	310	466	683	549	745	829	1093	1178
9	0,9	210	238	350	281	382	425	560	603
	2	295	336	492	395	536	596	787	848
	3	350	398	583	468	636	708	933	1006
	4	385	438	642	515	700	779	1027	1106
	5	415	472	692	555	755	839	1107	1193
	7	453	515	754	606	823	915	1207	1300
10	1	230	262	383	308	418	465	613	661
	2	308	350	513	412	559	622	820	884
	3	363	412	604	485	659	733	966	1042
	4	403	458	671	539	732	814	1073	1157
	6	465	529	775	622	845	940	1240	1336
	8	500	569	833	669	909	1011	1333	1437



- Area of influence of input pressure. (P1)
- Area of influence of reduced pressure. (P2)

Operation

The operation of the reducing valve is based on the principle of direct action. The force exerted by the spring displaces the axle and maintains the locking ball open. The fluid exerts an opposite force on the hood as it passes, which tends to reduce the section of passage of the fluid through the seating. The action of the spring and reaction of the pressure on the bellows balance each other, and the reduced pressure is maintained constant.

The fluctuations in consumption affect the reduced pressure. The bellows detects these variations via the balance hole, provoking a change in the passage of fluid as a function of the established reduced pressure.

In working conditions with zero consumption, the valve remains closed and completely airtight when there is a slight increase in reduced pressure.

Installation

- Always install the valve in a section of horizontal tubing, as close as possible to the point of consumption.
- The valve may be assembled in any position, even upside-down.
- Verify that the fluid flows in the direction indicated by the arrow on the body of the valve.
- The input and output tubes must be of the correct size and properly supported, to avoid any fall in pressure or tension.
- The output tubing should ideally have a greater diameter than the input tubing, to avoid excessive velocity of flow of the liquid.
- In accordance with the requirements of “Regulations for pressure devices ITC-MIE-AP 2 5.8”, the pressure reduction facilities in steam circuits will be supplied with:

1- A pressure gauge with syphon tube and three end cock, in accordance with article 11 of the MIE-AP 1 instructions, “Boilers”, located before and after the reduction valve.

2- A safety valve following the reduction valve, capable of evacuating the maximum flow of steam, which permits flow at the level regulated and adjusted to the maximum reduced pressure of service plus a maximum of 10%.

Example of installation for steam

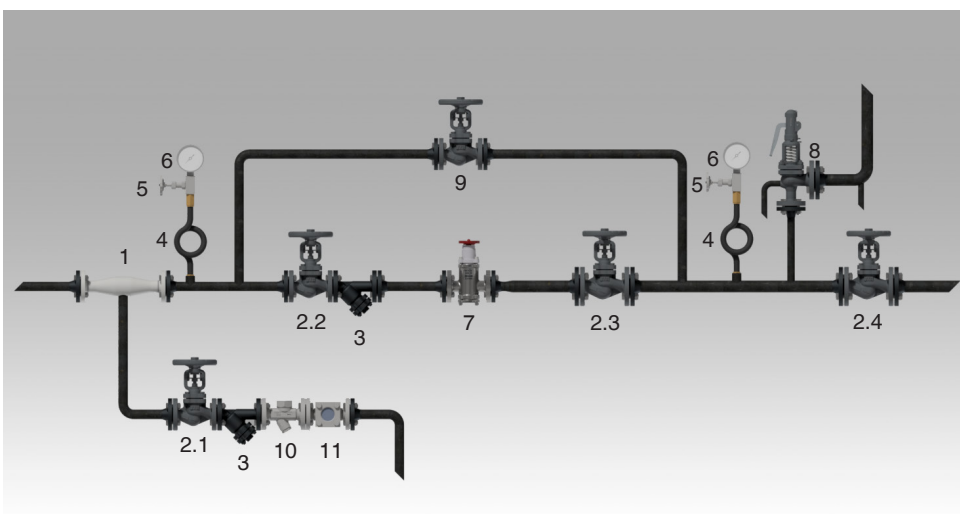

- 1** Condensate separator.
- 2** Interruption valve.
- 3** Filter.
- 4** Syphon tube.
- 5** Pressure gauge cock.
- 6** Pressure gauge.
- 7** Pressure reducing valve.
- 8** Safety valve.
- 9** Interruption valve with adjusting cone.
- 10** Condensate purger.
- 11** Window sight glasses.

IMPORTANT

- The distance between the pressure reducing valve **7** and the interruption valves **2.2** and **2.3** must be 8 ÷ 10 times the diameter of the tube.
- It is advisable to install the separator **1** and the condensate purger **10** using wet steam with dragging.
- We recommend that the reduction device be equipped with a by-pass and interruption valve with an adjusting cone **9**.

Start-up and adjustment of the reduced pressure

- 1- Before start-up, the tubes and the inside of the valve itself should be cleaned, eliminating any residues or impurities, particularly from the locking surfaces.
- 2- Check the rating plate (37) to verify that the regulation field for the reduced pressure is appropriate and that the spring (27) corresponds to the same range.
- 3- Remove the nut (38), the rating plate (37) and the anchoring bolt (36).
- 4- With the input interruption valve fully open and the output interruption valve closed, turn the handwheel (34) gradually from left to right to increase the reduced pressure, or from right to left to decrease it, until the required reduced pressure is obtained at zero consumption.
- 5- Slowly open the output interruption valve.
- 6- Readjust the required reduced pressure in consumption conditions.
- 7- Put the anchoring bolt (36) and the rating (37) in place, and fix with the nut (38).
- 8- Seal the valve to prevent further adjustments, using the sealing wire (33) and the seal (3).
- 9- We recommend that the input pressure P1 and the reduced pressure P2 be recorded in the corresponding space of the rating plate (37).

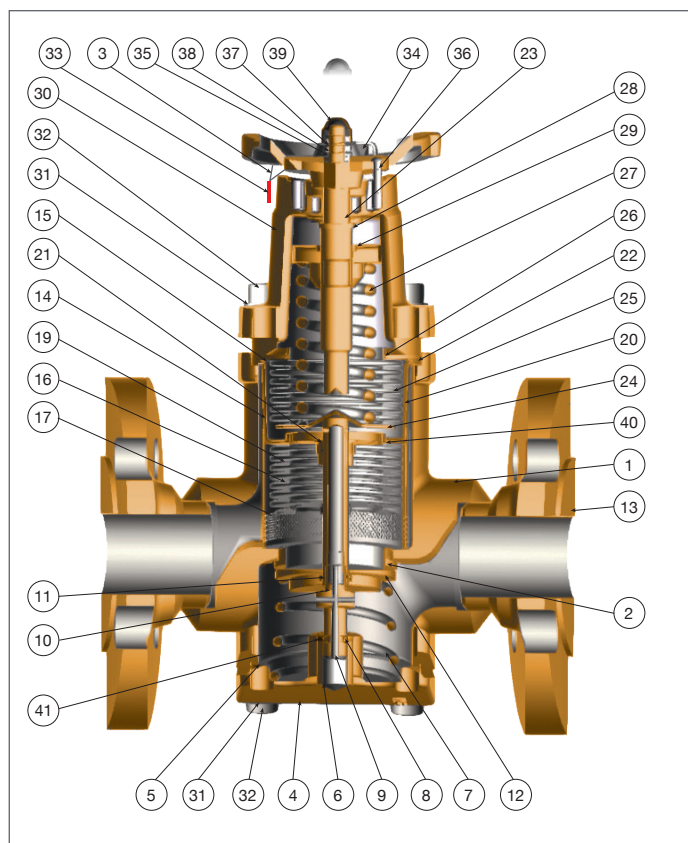

Disassembly and assembly

- 1- Unseal the valve by cutting the thread (33).
- 2- Remove the nut (38), type plate (37) and locking pin (36)
- 3- Turn the handwheel (34) from right to left until you feel the spring relax (27)
- 4- Unscrew the bolts (32) and remove them together with the washers (31).
- 5- Detach the cover (30) from the body (1) and you will gain access to some internal components. This facilitates easy maintenance or replacement of the spring (27), and the bellows (24) (25) (26).
- 6- Remove the bellows (16), (17), (18), (19), (20) and (40). This allows us to clean the filter (14).
- 7- Turn the valve and unscrew the bolts (32) and remove them.
- 8- Detach the cover (4) from the body (1) and you will gain access to some internal components. This allows us to easily maintain or replace the spring (7), components (12), (9) and (6) and the seat (2).
- 9- If the valve has been disassembled, replace the seals (22), (15) and (5) with new ones.
- 10- Insert the guide (9) and the spring (7) with the plug (12) and fix it with the cover (4) and the guide bush (6)
- 11- Place the cover (4) on the body (1) and screw in the bolts (32) after placing the washers (31).
- 12- Fit the filter (14) and thread the bellows (16), (17), (18), (19), (20) and (40).
- 13- Insert the regulating bolt (23) and the bellows (24), (25) and (26)
- 14- Select the appropriate spring (27) according to the reduced pressure.
- 15- Place the cover (30) on the body (1), place the bolts (32) together with the washers (31) and screw them in.
- 16- Finally, proceed according to the section "Commissioning and adjustment of the reduced pressure".

Maintenance

A correct installation with inlet and outlet stop valves facilitates maintenance.

The filter (14) should be cleaned periodically.

When accessing the valve assembly, replace the seals (22), (15) and (5) with new ones.