

ABO valve

we make processes work

KNIFE GATE VALVES

Body design

Interflanged

WAFER type with through holes
LUG with threaded holes

Nominal size

Series 200: DN50 - DN1200
Series 300: DN50 - DN600

Working pressure

2 bar / 4 bar / 6 bar / 10 bar

Flange connection

PN6 / PN10 / PN16 / Class 150

Working temperature

Series 200: -10 °C / +125 °C
Series 300: -10 °C / +200 °C

Working media

Waste water
Aqueous suspensions containing
solid particles
Slurry handling
Bulk materials
Sand
Dust media
Pulp
Paper stock
Mining suspensions
Abrasive media
Stock/Liquids in chemical industry

Features

Open design

Internal design of the seat
preventing sedimentation
blocking knife gate valve closing
Excellent flow-rate parameters
Minimal pressure drops
in piping system

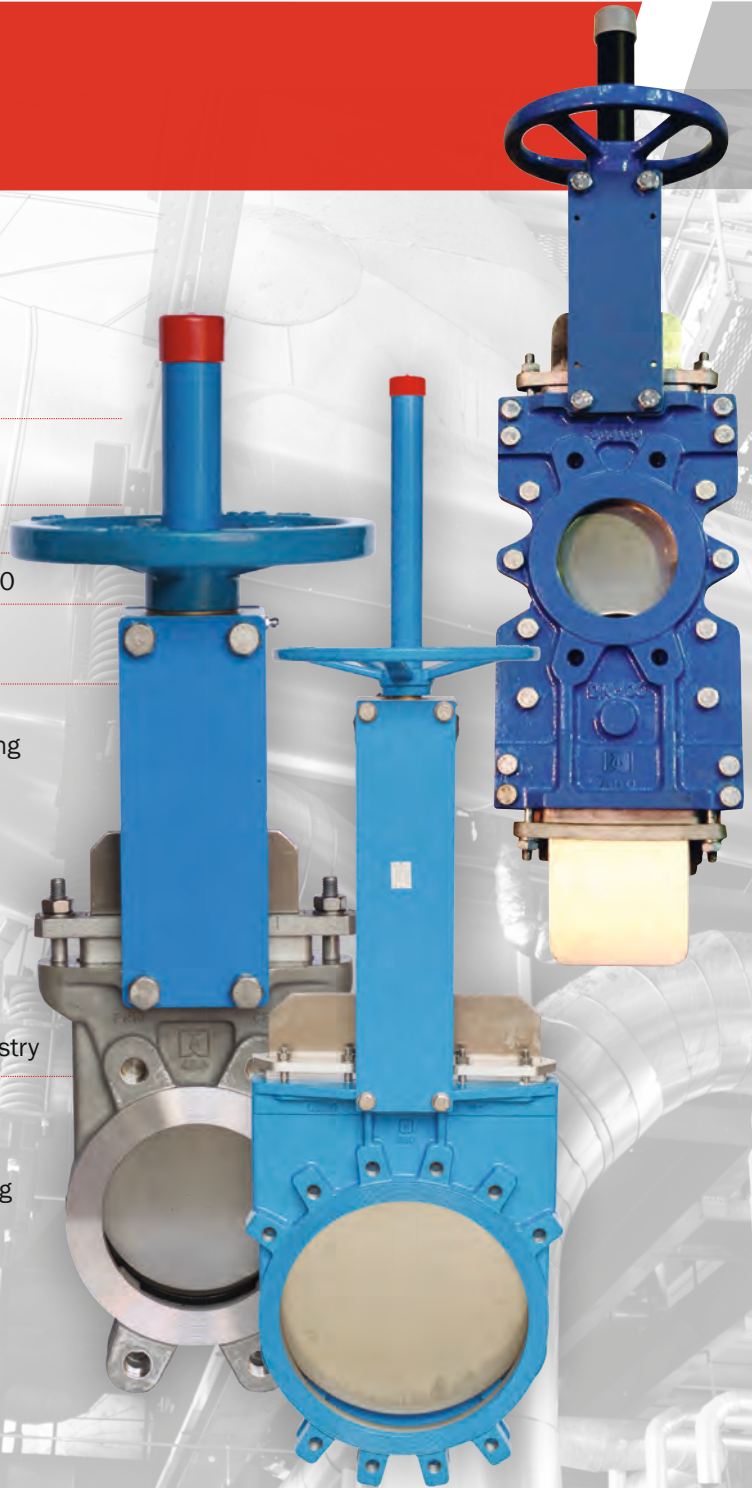

SERIES 200/300

www.abovalve.com

KNIFE GATE VALVES SERIES 200

Czech Industrial Valve Manufacturer

Knife gate valves Series 200 are unidirectional wafer/lug type knife gate valves ideal for installations handling liquids containing suspended solids and waste water (mining, chemical treatment, water treatment, etc.).

Thanks to their small size and light weight, are especially useful in facilities with limited space. Long-life service of the product is secured as a circular blade bevel prevents excessive wear and clogging (leakage). The valve is reinforced with oversize top and bottom ends to ensure proper sealing. Beveled knife hacks away fibrous particles, moving them towards a self-cleaning bottom area and rinsing them out of the saddle.

The valve can be manufactured with bonnets which provide for total water tightness towards the outside environment, thereby reducing the maintenance of the packing gland.

ABO knife gate valves series 200 are ideal for installations handling liquids which contain suspended solid and waste water. They are used in following applications:

- slurry handling
- bulk materials conveying
- mining industry
- chemical industry
- waste water treatment
- pulp and paper industry

Basic properties

- unidirectional knife gate valve with rising stem and one-piece body
- knife goes through the sealing area
- circular, total passage: enables a high flow capacity with low load loss
- gate with rounded edges: prolongs the working life of the rings and packing
- seating wedges help the knife to close against the body and seat
- directional arrow in the body points the correct mounting position
- high flow rate with low pressure drops
- internal design avoids any build up of solids that would prevent the valve from closing
- recommended for water with a maximum 5% concentration of solid particles
- can be combined with various kinds of drives and actuators (handwheel, electric, pneumatic actuator, etc)



Type designation

2 1 0 B 100 5

Actuation

- 1 - handlever
- 2 - handwheel
- 3 - gearbox
- 4 - pneumatic actuator
- 5 - electric actuator

Nominal size (DN)

Body type

- B - WAFFER
- T - LUG

Seat material *)

- 1 - NBR
- 2 - EPDM
- 4 - Viton

Body & knife material

- 1 - Body: grey cast iron 0.6025 (GG25)
Knife: stainless steel 1.4306 (AISI 304 L)
- 2 - Body: stainless steel 1.4408 (CF8M)
Knife: stainless steel 1.4404 (AISI 316 L)

Series name

Series 200

*) other materials upon request

Standards

Leak test

EN 12266-1, Class A*)
ISO 5208, Class A*)
API 598, Tab. 5
*) for soft seated version

Connection between flanges

EN 1092-1
DIN 2632
DIN 2566

Marking

EN 19

Models

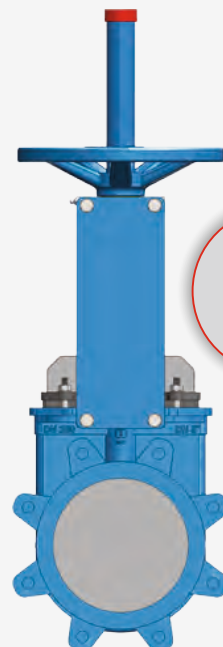
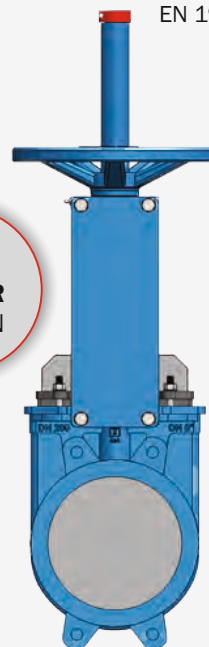

DESIGN ADVANTAGES - SERIES 200

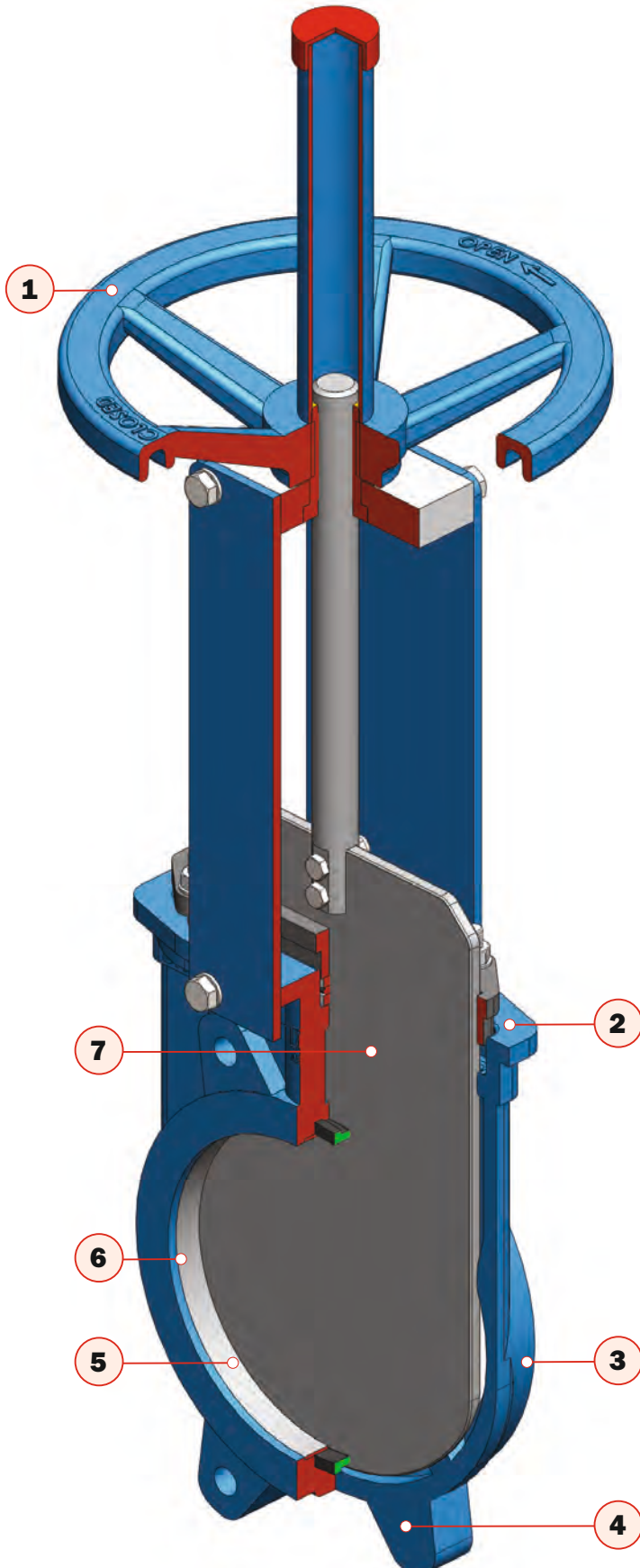

1. Interchangeable drives

- manual actuation is conducted through a handwheel. Also can be combined with a wide range of pneumatic and electric actuators.

2. Solid, durable body casting

- the solid iron body of ABO Series 200 knife gate valves has been designed to handle mechanical wear, and thus to provide for a durable solution in severe service conditions.

3. Minimal pressure drops

- a specially profiled body on the internal part prevents pressure drops with high media velocity.

4. Connection between flanges

- as standard, connection between flanges is designed as per EN 1092. However, the body design allows for variable connection options as per other norms.

5. Simple seat replacement

- the sealing design backed by the reinforcement ring allows for an easy and quick replacement of the sealing elements.

6. Seat option

- multiple seat options available. Please refer to pages 4 and 5.

7. Excellent tightness

- state of the art machining, as well as precise casting technology of individual components, results in a perfect shut-off and guarantees class A tightness
- Bi-directional seal available

SEATS / SURFACE TREATMENT

Czech Industrial Valve Manufacturer

Seats options

EPDM

▪ ABO EPDM seat is suitable for application with temperatures ranging from -25°C to $+125^{\circ}\text{C}$. EPDM has excellent resistance to heat, ozone and sunlight, very good flexibility at low temperature, good resistance to alkalis, acids and oxygenated solvents. It has poor resistance to oil, gasoline and hydrocarbon based solvents. Typical applications for this material are clean water and waste water service, pulp and paper, or applications in the sugar refining industry.

NBR

▪ ABO NBR seat is suitable for applications with temperatures ranging from -10°C to $+90^{\circ}\text{C}$. NBR has very good resistance to oil, gasoline, alkalis and acids, as well as to hydrocarbon based solvents. NBR has inferior resistance to ozone and oxygenated solvents, as well as to high polar solvents. Typical applications for this material is water contaminated with oils or grease.

VITON

▪ ABO VITON seat is suitable for applications with temperatures ranging from -25°C to $+150^{\circ}\text{C}$. VITON has very good resistance to ozone and sunlight, is compatible with a broad spectrum of chemicals, salts solutions and may be used on bleached paper lines. ABO VITON has very good resistance to alkalis and acids. It is not suitable for steam or hot water service.

Body surface treatment

Epoxy coating

ABO standard coating option (RAL 5015) is premium quality epoxy grade C2 coating with minimal thickness of 80 microns (EN12904-1).

Marine coating

Marine coating for highly abrasive media, especially in marine environment, is an option. Grades C3, C4 and C5 are available.

Rilsan coating

Rilsan (Nylon 11) coating, providing superb corrosion resistance, is an option on selected valve components. This coating option is recommended for applications such as seawater, cement, food or water service contaminated with chemicals.

Halar coating

Halar coating provides for high impact strength, resistance to wide range of chemicals, acids and also severe corrosion and friction. Further, Halar coating is a suitable solution for cryogenic applications.

Inter Zone 954

Coating provides superior protection in sea water environment. The coating is designed for bodies exposed to high humidity or other very arduous climate conditions. It is highly resistant to acid and solvent vapours and sprinkles, common and salt water.



Clean water treatment application



Sewage water treatment application

SEAT OPTIONS

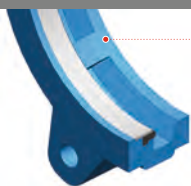

1. Soft seat

Standard soft seat design suitable for water service, and for liquids with a maximum solid concentration of 5% (Class A tightness rate).

2. Metal seat

Metal seat design (knife closes against the body directly) with maintenance-free seat. This solution is suitable for usage in bulk handling applications, such as solids, powders and sands. Not suitable for water and liquids applications.



3. Soft seat with deflecting cone 15°

Soft seat design with a deflecting cone of 15° as accessory. This solution is particularly suitable for fluids with larger solid particles whereby damage of the body/internals can occur.

4. Metal seat with deflecting cone 15°

Metal seat design with a deflecting cone of 15° as accessory. This solution is particularly suitable for solid or powder media with larger solid particles whereby damage of the body/internals can occur.

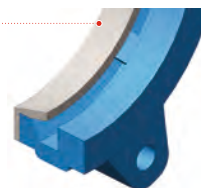

5. Soft seat with scraper 8°

Soft seat design with reinforced sealing ring of 8° in casted material securing a higher degree of protection for the seating element. This solution is used for medias with high velocity or higher pressure. This solution is used for pulp with solids or staples, or meat factories with bone particles.

6. Soft seat with deflecting cone 15° and scraper 8°

Soft seat design with reinforced sealing ring of 8° and a deflecting cone of 15° as accessory. This solution gives more protection to the internals parts thanks to the cone (restriction of bore), and is suitable in severe abrasive service such as mining service, whereby water with slurries or sand is present.

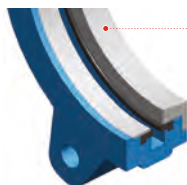
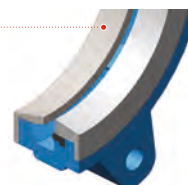

7. Bidirectional seat

Standard soft seat bidirectional design with a flat fixing ring and a scraper. This solution is suitable for water and sewage service whereby a reversed flow of the media can occur.

8. Bidirectional reinforced seat

Soft seat bidirectional design with reinforced sealing ring of 8° in casted material secures a higher degree of protection of the seating element. This solution is used for medias with high velocity or higher pressure, and in situations whereby a reversed flow of the media can occur.

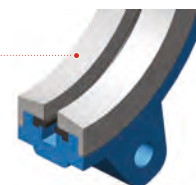

MATERIAL PERFORMANCE / TECHNICAL INFORMATION

Czech Industrial Valve Manufacturer

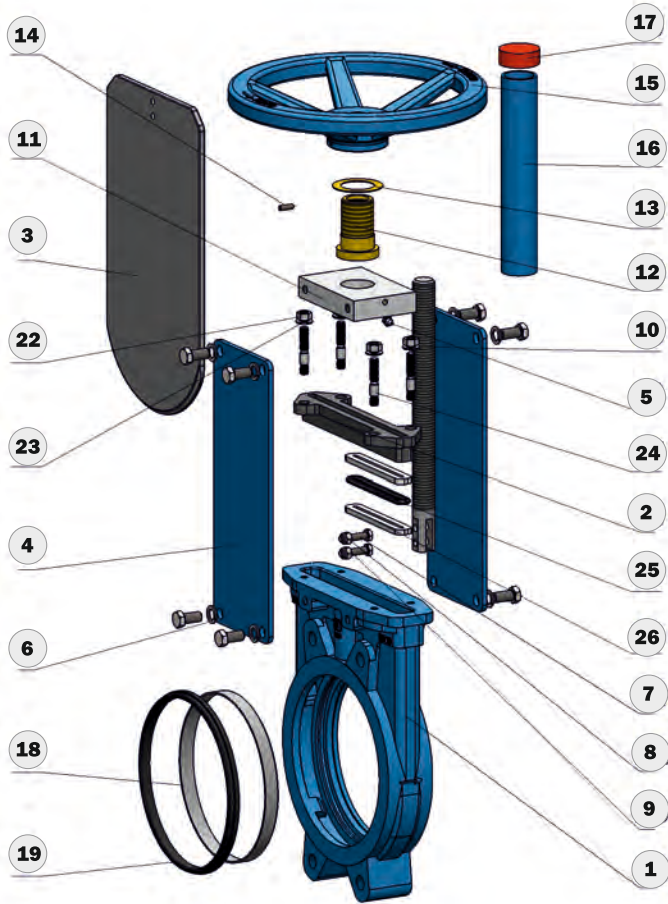

Pos.	Name	Material 1	Material 2
1	Body	Cast iron 0.6025 (GG25)	Stainless steel 1.4408 (CF8M)
2	Packing gland	Aluminium 3.2581	Stainless steel 1.4408 (CF8M)
3	Knife	Stainless steel 1.4306 (AISI 304 L)	Stainless steel 1.4404 (AISI 316 L)
4	Support plate	Steel 1.0036	Steel 1.0036
5	Greaser	Steel 1.0553 + Zinc	Steel 1.0553 + Zinc
6,13 23	Washer	Stainless steel A4	Stainless steel A4
7,8	Bolt	Stainless steel A4	Stainless steel A4
9,22	Nut	Stainless steel A4	Stainless steel A4
10	Stem	Stainless steel EN 1.4305 (AISI 303)	Stainless steel EN 1.4305 (AISI 303)
11	Support plate	Brass 2.0402	Brass 2.0402
12	Stem nut	Brass 2.0402	Brass 2.0402
14	Lock washer	Stainless steel A4	Stainless steel A4
15	Hand-wheel	Cast iron 0.6025 (GG25)	Cast iron 0.6025 (GG25)
16	Tube	Steel 1.0036	Steel 1.0036
17	Cover	Plastic	Plastic
18	Sealing ring	Stainless steel 1.4404 (AISI 316 L)	Stainless steel 1.4404 (AISI 316 L)
19	Seat	EPDM	EPDM
20	Deflecting cone	Stainless steel 1.4401 (AISI 316)	Stainless steel 1.4401 (AISI 316)
21	Reinforced ring	Stainless steel 1.4401 (AISI 316)	Stainless steel 1.4401 (AISI 316)
21	Nut	Stainless steel A4	Stainless steel A4
24	Pivots	Stainless steel A4	Stainless steel A4
25	Stuffing O-ring	EPDM	EPDM
26	Stuffing box	Synthetic yarn + PTFE	Synthetic yarn + PTFE

Installation between flanges DN50 - DN1200, DESIGN „B”

DN	50	65	80	100	125	150	200	250	300	350	400	450	500	600	700	800	900	1000	1200	
NPS	2"	2½"	3"	4"	5"	6"	8"	10"	12"	14"	16"	18"	20"	24"	28"	32"	36"	40"	48"	
PN6	•	•	•	•	•	•	•	•	•	•	•	•	•	•	•	•	•	•	•	•
PN10																				
PN16	•	•	•	•	•	•	•	•	•	•	•	•	•	•	•	•	•	•	•	•
Class 150	•	•	•	•	•	•	•	•	•	•	•	•	•	•	•	•	•	•	•	•

standard

• on request

• impossible

Operating torques (Nm) vs. working pressure (bar)

DN	50	65	80	100	125	150	200	250	300	350	400	450	500	600
NPS	2"	2½"	3"	4"	5"	6"	8"	10"	12"	14"	16"	18"	20"	24"
p_{max} 10 bar	10	12	15	20	25	30	35	45	60	70	90	100	110	170

Operating torques above are valid for electric actuator. Operating torques are mentioned without safety reserve.

BASIC DIMENSIONS

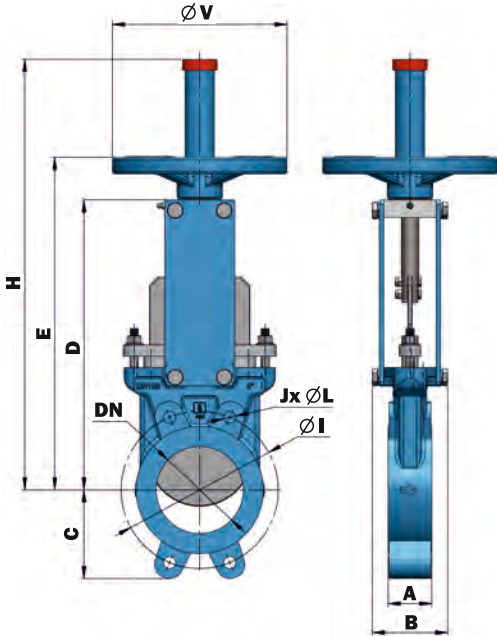

DN	A	B	C	D	E	H	I	J	L	V	Kg (type B)
50	40	86	60	241	290	370	125	4	M16	200	8
65	40	86	68	267	316	400	145	4	M16	200	9
80	50	86	90	293	342	454	160	8	M16	200	10,5
100	50	86	102	332	381	494	180	8	M16	200	11,5
125	50	96	119	369	428	555	210	8	M16	250	15
150	60	96	130	419	478	626	240	8	M20	250	20
200	60	116	160	519	593	793	295	12	M20	305	32
250	70	116	202	636	710	937	350	12	M20	305	45
300	70	116	224	740	814	1 120	400	12	M20	305	58
350	96	193	261	912	987	1 136	460	16	M20	410	108
400	100	193	295	984	1 059	1 470	515	16	M24	410	130
450	106	193	318	1 055	1 130	1 640	565	20	M24	510	160
500	110	193	345	1 188	1 263	1 780	620	20	M24	510	193
600	110	290	400	1 378	1 453	2 070	725	20	M27	510	283

DN	A	B	C	D	E	F	G	ØK	P	
									Holes No.	PN10
700	460	2 501	1 646	855	838	110	408	840	24	M27
800	503	2 788	1 833	955	970	110	408	950	24	M30
900	586	3 149	2 094	1 055	1 040	110	408	1 050	28	M30
1000	620	3 439	2 284	1 155	1 150	110	408	1 160	28	M33
1200	755	4 159	2 804	1 355	1 450	150	460	1 380	32	M33



Transportation of bulk solids



Mixing chamber installation

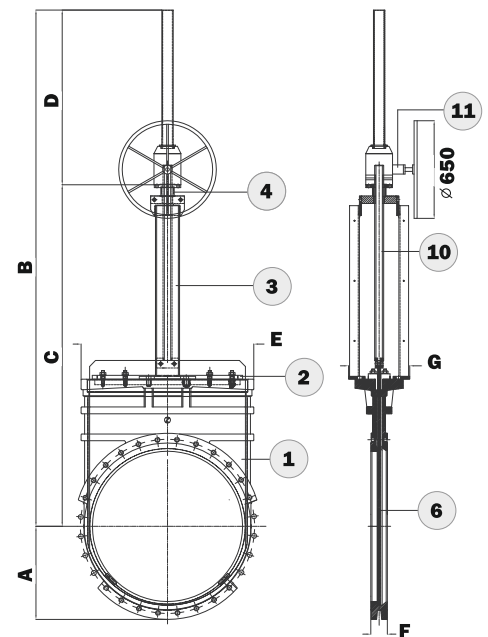

Working conditions

Working pressure max.	Seats temperature rating
DN50-DN250: 10 bar	-25 °C do +125 °C (EPDM)
DN300-DN400: 6 bar	-10 °C do +90 °C (NBR)
DN500-DN600: 4 bar	-25 °C do +150 °C (Viton)
DN700-DN1200: 2 bar	

KNIFE GATE VALVES SERIES 300

Czech Industrial Valve Manufacturer

Knife gate valves Series 300 are the most common of the so-called through conduit valves. Series ABO 300 is a wafer type bidirectional valve which is ideal for installations handling large solids, very viscous fluids, sludge and highly concentrated slurry (mining, paper industry, cement industry, etc.). The main characteristic of the blade is that it passes through the entire length of the body. A round outlet is machined in the middle of each blade. This outlet, while falling with identical outlet on the valve body, allows for maximum direct flow of the medium. Thus, while being in open position, the valve essentially becomes part of the piping (leading to dead zones elimination).

ABO knife gate valves series 300 are ideal for installations handling liquids which contain suspended solid and waste water. They are used in following applications:

- mining industry
- chemical industry
- slurry handling
- waste water treatment
- pulp and paper industry

Basic properties

- bidirectional design with two-piece body with rising stem
- knife goes through the sealing area
- circular, total passage: enables a high flow capacity with low load loss
- through the gate - in the open position there are not places that restrict the flow
- sided seal - seal and support ring on both sides
- can be combined with various kinds of actuators (handwheel, electric actuator, pneumatic actuator, etc)



Type designation

3 1 0 B 100 5

Actuation

- 1 - handlever
- 2 - handwheel
- 3 - gearbox
- 4 - pneumatic actuator
- 5 - electric actuator

Nominal size (DN)

Body type
B - WAFER

Seat material *)

- 1 - NBR
- 2 - EPDM
- 4 - Viton

Body & knife material

- 1 - Body: grey cast iron 0.6025 (GG25)
Knife: stainless steel 1.4306 (AISI 304 L)
- 2 - Body: stainless steel 1.4408 (CF8M)
Knife: stainless steel 1.4404 (AISI 316 L)

Series name

Series 300

*) other materials upon request

Standards

Leak test

EN 12266-1, Class A*)
ISO 5208, Class A*)
API 598, Tab. 5
*) for soft seated version

Connection between flanges

EN 1092-1

Marking

EN 19

Body type

B
WAFER
DESIGN

Working conditions

Working pressure max.	Temperature rating
DN50-DN250: 10 bar	- 25 °C do +125 °C (EPDM)
DN300-DN400: 6 bar	- 10 °C do +90 °C (NBR)
DN500-DN600: 4 bar	- 25 °C do +150 °C (Viton)

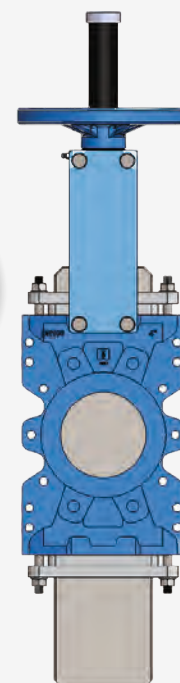

DESIGN ADVANTAGES - SERIES 300

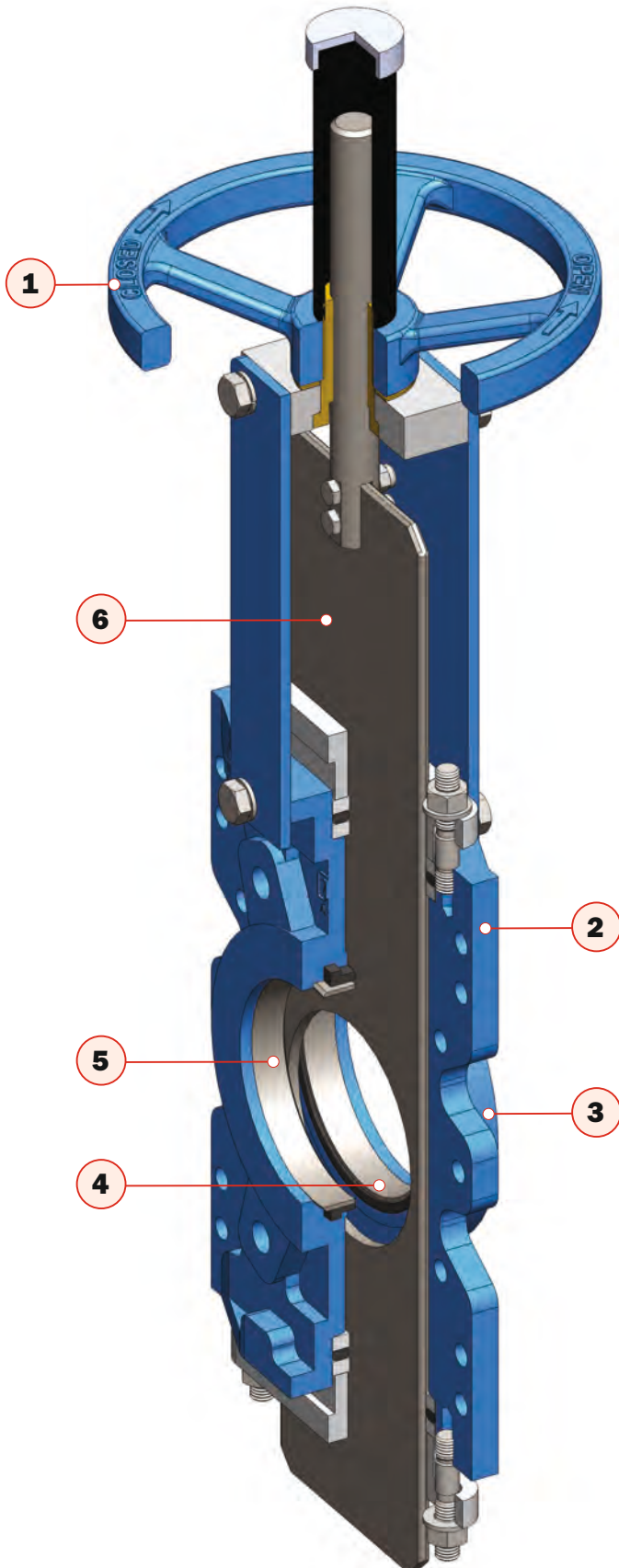

1. Interchangeable drives

- manual actuation is conducted through a handwheel. Also can be combined with a wide range of pneumatic and electric actuators.

2. Robust body casting

- a two-piece body design allows for an easy replacement of internal components.

3. Connection between flanges

- as standard, connection between flanges is designed as per EN 1092. However, the body design allows for variable connection options as per other norms.

4. Profiled body shape

- a specially designed internal body shape prevents particles from entering into the sealing area and thus potentially decreasing the functionality of the valve.

5. Bidirectional sealing

- state of the art machining, as well as precise casting technology of individual components, results in a perfect shut-off and guarantees class A tightness.

6. Excellent Bi-directional tightness

- in order to avoid leakage while moving the knife, packing has been installed in the upper as well as the lower part of the body. The packing system is further reinforced by metal rings and counterflanges. "Metal-Metal" design is not bi-directionally tight, nor "A" class tightness.

MATERIAL PERFORMANCE / TECHNICAL INFORMATION

Czech Industrial Valve Manufacturer

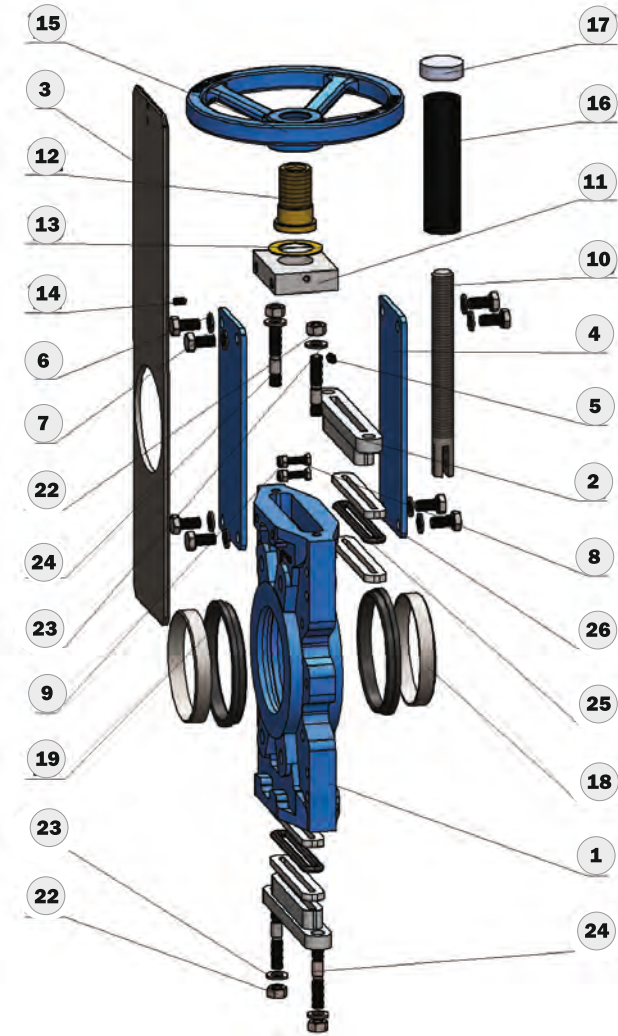

Pos.	Name	Material 1	Material 2
1	Body	Cast iron 0.6025 (GG25)	Stainless steel 1.4408 (CF8M)
2	Packing gland	Aluminium 3.2581	Stainless steel 1.4408 (CF8M)
3	Knife	Stainless steel 1.4306 (AISI 304 L)	Stainless steel 1.4404 (AISI 316 L)
4	Support plate	Steel 1.0036	Steel 1.0036
5	Greaser	Steel 1.0553 + Zinc	Steel 1.0553 + Zinc
6,13 23	Washer	Stainless steel A2 (poz. 13 Mosaz 2.0402)	Stainless steel A2 (poz. 13 Mosaz 2.0402)
7,8	Bolt	Stainless steel A2	Stainless steel A2
9,22	Nut	Stainless steel A2	Stainless steel A2
10	Stem	Stainless steel EN 1.4305 (AISI 303)	Stainless steel EN 1.4305 (AISI 303)
11	Support bridge	Steel 1.0036	Steel 1.0036
12	Stem drive nut	Brass 2.0402	Brass 2.0402
14	Stop screw	Stainless steel 1.4301 (AISI 304)	Stainless steel 1.4301 (AISI 304)
15	Hand-wheel cover	Cast iron 0.6025 (GG25)	Cast iron 0.6025 (GG25)
16	Stem cover	Steel 1.0036	Steel 1.0036
17	Cover	Plastic	Plastic
18	Sealing ring	Stainless steel 1.4404 (AISI 316 L)	Stainless steel 1.4404 (AISI 316 L)
19	Seat	EPDM	EPDM
20	Deflecting cone	Stainless steel 1.4401 (AISI 316)	Stainless steel 1.4401 (AISI 316)
21	Reinforced ring	Stainless steel 1.4401 (AISI 316)	Stainless steel 1.4401 (AISI 316)
21	Nut	Stainless steel A2	Stainless steel A2
24	Pivots	Stainless steel A2	Stainless steel A2
25	Stuffing O-ring	EPDM	EPDM
26	Stuffing box	Synthetic yarn + PTFE	Synthetic yarn + PTFE

Installation between flanges DN50 - DN600, DESIGN B

DN	50	65	80	100	125	150	200	250	300	350	400	450	500	600
NPS	2"	2½"	3"	4"	5"	6"	8"	10"	12"	14"	16"	18"	20"	24"
PN6	•	•	•	•	•	•	•	•	•	•	•	•	•	•
PN10														
PN16	•	•	•	•	•	•	•	•	•	•	•	•	•	•
Class 150	•	•	•	•	•	•	•	•	•	•	•	•	•	•

■	standard
•	on request
✗	impossible

Operating torques (Nm) vs. working pressure (bar)

DN	50	65	80	100	125	150	200	250	300	350	400	450	500	600
NPS	2"	2½"	3"	4"	5"	6"	8"	10"	12"	14"	16"	18"	20"	24"
p_{max} 10 bar	10	12	15	20	25	30	35	45	60	70	90	100	110	170

Operating torques above are valid for electric actuator. Operating torques are mentioned without safety reserve..

SEAT OPTIONS

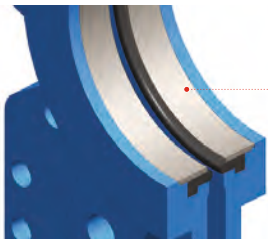

1. Soft seat

Standard soft seat design (EPDM, NBR, PTFE) cutting, suitable for water service, and for liquids with a maximum solid concentration of 5 % (Class A tightness rate).



2. Metal seat

Metal seat design (knife closes against the body directly) with maintenance-free seat is typically suitable for applications handling dense paper pulp. Not suitable for water and liquids applications. In fully open position, the valve is a perfect continuation of the pipe as it eliminates dead spaces. Bi-directional design is not possible in this variant.

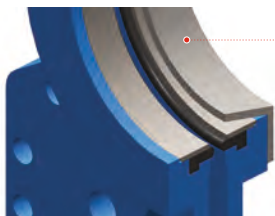

3. Soft seat with deflecting cone 15°

Soft seat design with a deflecting cone of 15° as accessory is particularly suitable for solid or powder media with larger solid particles whereby damage of the body/internals can occur. This solution is frequently used in bulk industry for services with abrasive fluids.



4. Metal seat with deflecting cone 15°

Metal/metal seat design with a deflecting cone of 15° as accessory is particularly suitable for solid or powder media with larger solid particles whereby damage of the body/internals can occur.



5. Soft seated with scraper 8°

Soft seat bidirectional design with reinforced sealing ring of 8° in casted material securing a higher degree of protection for the seating element. This solution is used for medias with high velocity or higher pressure, and in situations whereby a reversed flow of the media can occur. This solution is used for pulp with solids or staples in dumping outlet, dump chest drains and heavy rejects.

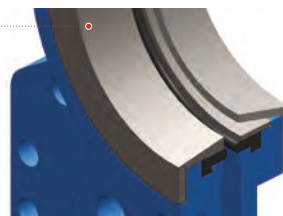

6. Soft seated with deflecting cone 15° and scraper 8°

Soft seat design with reinforced sealing ring of 8° and a deflecting cone of 15° as accessory. This solution gives more protection to the internals parts thanks to the cone (restriction of bore), and is suitable in severe abrasive service such as mining service, whereby water with slurries or sand is present.

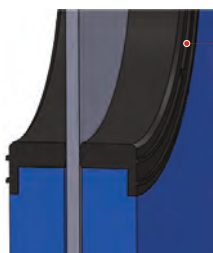

7. Soft seated rubber sleeve

Special seat design with 2 rubber sleeves for abrasive service. This solution is particularly suitable for solid or powder media with larger solid particles whereby damage of the body/internals can occur. Frequently used in mining industry for medias with abrasive fluids.

BASIC DIMENSIONS - SERIES 300

Czech Industrial Valve Manufacturer

DN	A	B	C	D	E	øV
50	40	90	220	284	425	200
65	40	90	260	308	450	200
80	50	90	303	334	480	200
100	50	90	360	374	520	200
125	50	100	428	413	600	250
150	60	100	493	465	650	250
200	60	120	632	528	820	300
250	70	120	767	682	1 020	300
300	70	120	897	782	1 120	300
350	96	192	1 042	898	1 380	400
400	100	192	1 167	1 003	1 490	400
450	106	192	1 297	1 093	1 580	500
500	110	192	1 455	1 207	1 690	500
600	110	290	1 705	1 410	2 030	500

DN	øK		P		
	PN10	ANSI 150	Holes No.	PN10	ANSI 150
50	120	120,6	4	M16	W 5/8"
65	145	139,7	4	M16	W 5/8"
80	160	152,4	8	M16	W 5/8"
100	180	190,5	8	M16	W 5/8"
125	210	215,9	8	M16	W 3/4"
150	240	241,3	8	M20	W 3/4"
200	295	298,4	8	M20	W 3/4"
250	350	361,9	12	M20	W 7/8"
300	400	431,8	12	M20	W 7/8"
350	460	476,2	16	M20	W 1"
400	515	539,7	16	M24	W 1"
450	565	577,8	20	M24	W 1 1/8"
500	620	635,0	20	M24	W 1 1/8"
600	725	719,3	20	M27	W 1 1/8"

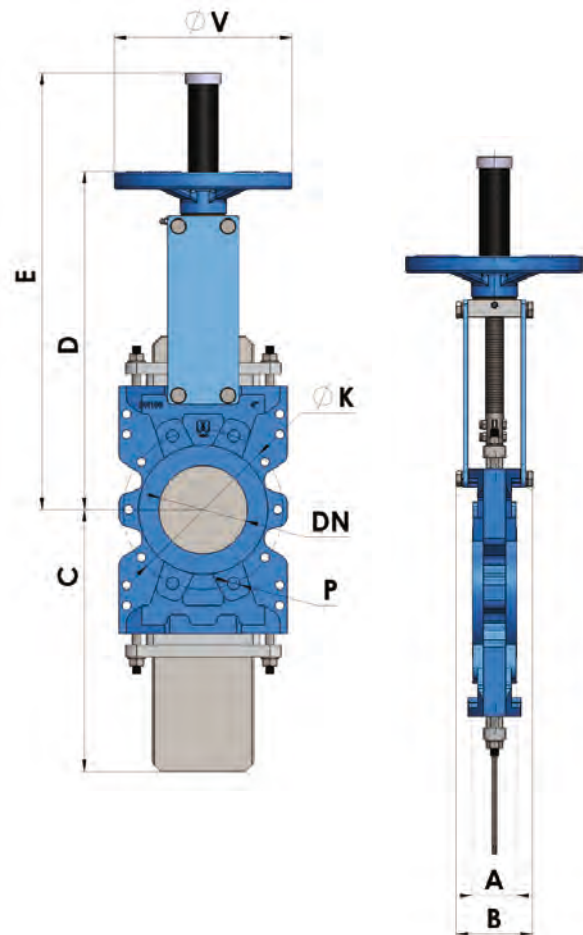

Valid since: 09/2021



Follow us on:



www.abovalve.com



Czech Republic

ABO valve, s.r.o.
Dalimilova 285/54
783 35 Olomouc
tel.: +420 585 224 087
sales@abovalve.com

Slovak Republic

ABO Slovakia, s.r.o.
Banská Bystrica
tel.: +421 484 145 633
sales.sk@abovalve.com

Germany

ABO Armaturen GmbH
Essen
tel.: +49 (0)152 262 29501
sales.de@abovalve.com

Russia

ABO Armatura LLC
Smolensk
tel.: +7 (4812) 240 020
sales.ru@abovalve.com

Ukraine

ABO Ukraine LLC
Dnipro
tel.: +38 056 733 95 70
sales.ua@abovalve.com

Turkey

ABO Armaturen LTD STI
Istanbul
tel.: +90 216 527 36 34
sales.tr@abovalve.com

China

ABO Flow Control
Shanghai
tel.: +86 136 01 522 831
sales.cn@abovalve.com

India

ABO Controls Pvt. Ltd.
Mumbai
tel.: +91 99 2002 9994
sales.in@abovalve.com

Singapore

ABO Valve Pte. Ltd.
Singapore
tel.: +65 9169 4562
sales.sg@abovalve.com

United Arab Emirates

Sales representation
Abu Dhabi
tel.: +971 56 9207964
bharti@abovalve.com

Bahrain

Sales representation
Manama
tel.: +973 3444 9065
jimmichen@abovalve.com

The technical information described in this leaflet is tentative and for general use only and does not constitute a recommendation or guarantee for any specific service or application requirement. Please consult ABO representative or factory for specific requirements and material selection for your intended application. The right to change or modify product design or product without prior notice is reserved. ABO valve accepts no liability for damages caused by bad interpretation or use of the information included in this brochure.