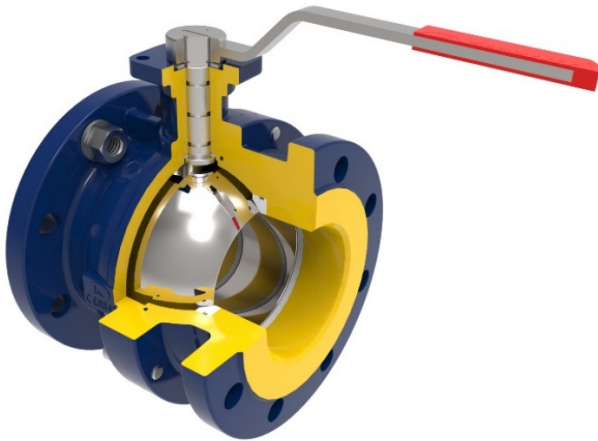

FIG.565



BALL VALVE zBAL



Body material	Nominal pressure	Nominal diameter	Max. temperature
A Grey cast iron	C 16 bar*	DN 15-250	150°C
C Nodular cast iron	C 16 bar*	DN 15-200	150°C
I Cast stainlesssteel	C 16bar	DN 15-200	220°C

*upon special request PN 10



correspond to the pressure equipment directive 2014/68/UE marking CE for DN≥32

FEATURES

- high tightness (leakproofness class - A acc. to EN -12266 - 1)
- compact settlement
- environment-friendly
- tests acc. to EN - 12266 - 1
- flanges drilled according to EN 1092-1 ; EN 1092-2
- face-to-face dimension according to EN 558 series 14 for A, C (DN 15-150); I (DN15-100)
- face-to-face dimension according to EN 558 series 15 for A, C (DN 200-250); I (DN125-200)

APPLICATION

industries



INDUSTRY



SHIPBUILDING
INDUSTRY



HEATING

media



GLYCOL



INDUSTRIAL
WATER



COMPRESSED AIR



NEUTRAL FLUIDS

Data given can be changed without notice.

Edition 01/2026

FIG.565

MATERIALS

Material A i C

DN15-150

DN200

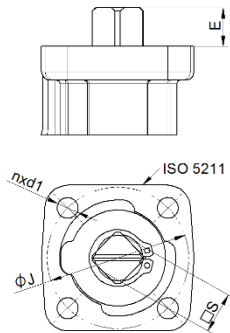
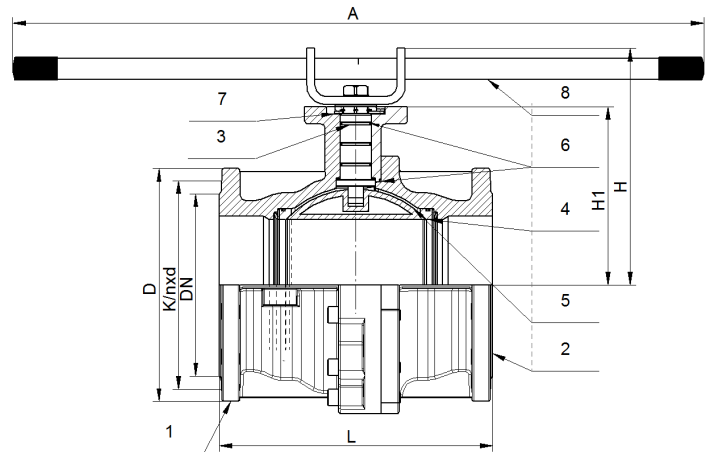
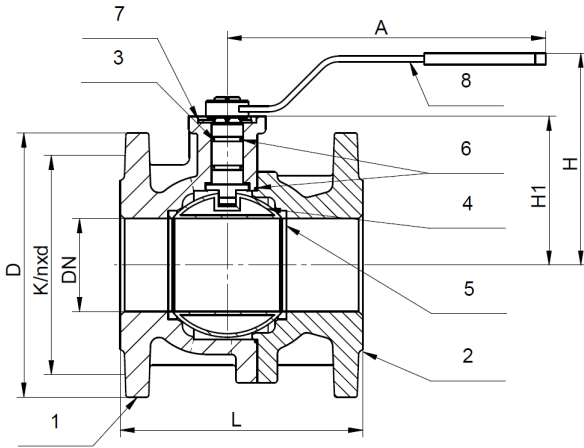

DN 250

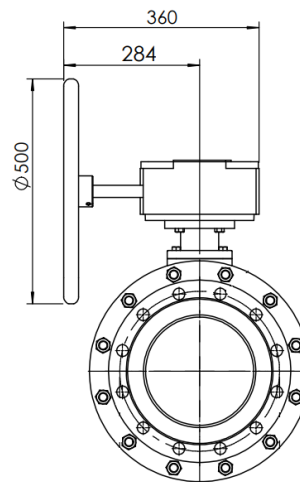
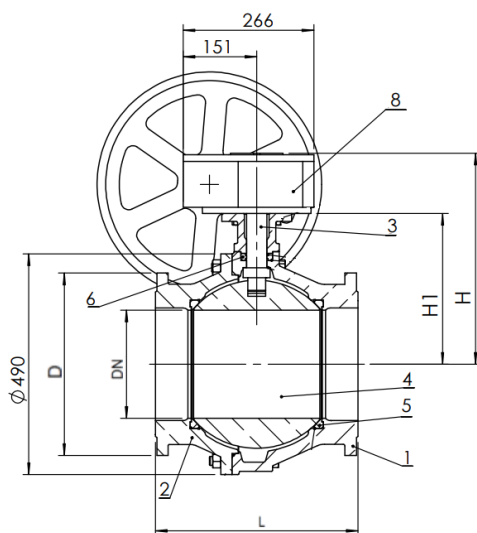

Chiavetta 14x60
ISO R773 / DIN6885A

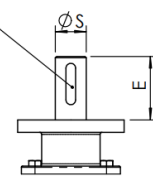

ISO5211 nx phi d



Data given can be changed without notice.

Edition 01/2026

FIG.565

Material I

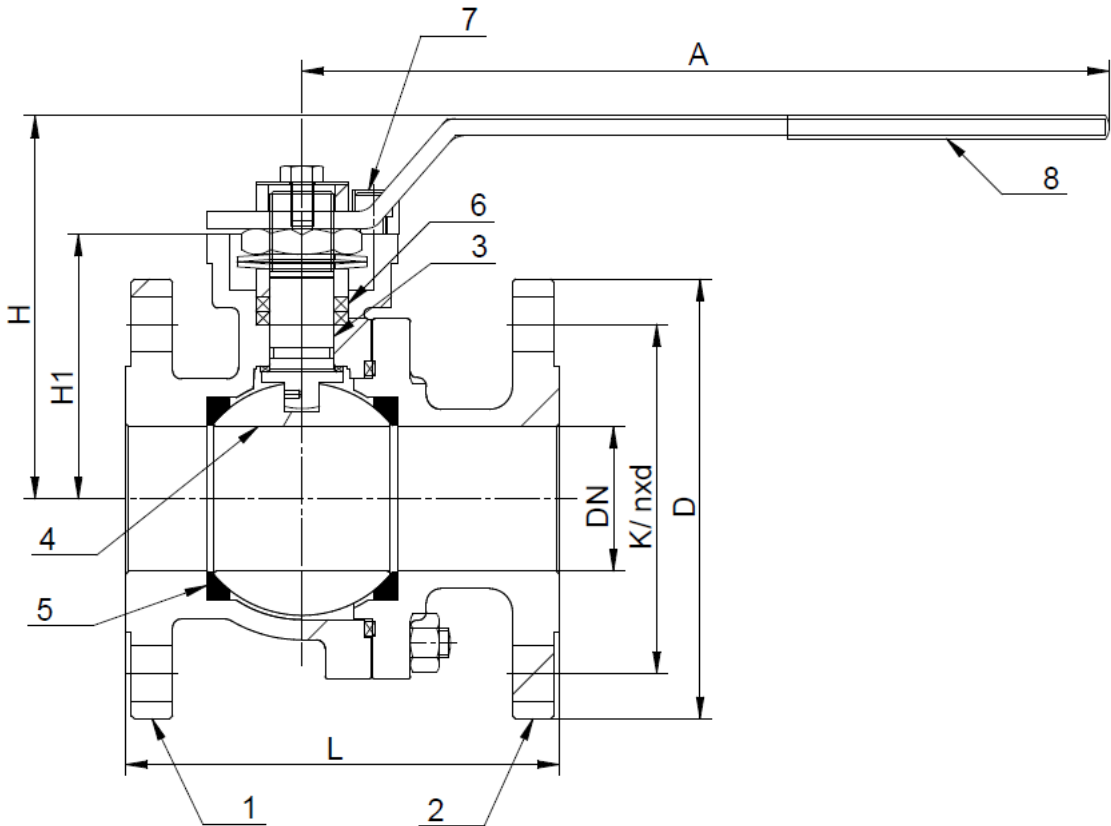

	Body material	A	C	I
	Type	09	09	09
1	Body	EN – GJL-250 5.1301 (ex. JL 1040)	EN – GJS-400– 18LT 5.3103 (ex. JS 1025)	X5CrNiMo17-12-2 1.4401
2	Ends	EN – GJL-250 5.1301 (ex. JL 1040)	EN – GJS-400– 18LT 5.3103 (ex. JS 1025)	X5CrNiMo17-12-2 1.4401
3	Stem	X2Cr13 1.4021		X5CrNiMo17-12-2 1.4401
4	Ball	X5CrNi18-10 1.4301		X5CrNiMo17-12-2 1.4401
5	Ball seat	PTFE		PTFE
6	O-ring	EPDM*		GRAFOIL
7	Opening limiter	Steel		Steel
8	Lever***	Steel		Steel
	Max. temperature	150°C**		220°C

* upon special request – FKM

** for FKM

*** for material A, C - DN 250 and material I DN 200 gearbox

Data given can be changed without notice.

Edition 01/2026

FIG.565
DIMENSIONS (A, C)

DN	15	20	25	32	40	50	65	80	100	125	150	200	250	
L (mm) A, C	115	120	125	130	140	150	170	180	190	200	210	400	450	
A (mm)	173	173	173	173	223	223	223	255	255	502	502	1000	---	
H (mm)	98	101	106	116	132	139,5	149	173	198	194	211	345	448	
H1 (mm)	53,5	56	61	71	86	93	104	125	150	180	197	260	335	
ISO 5211	F04	F04	F04	F04	F05	F05	F05	F07	F07	F10	F10	F12	F12	
E (mm)	8,5	8,5	10	10	13	13,5	13,5	15,5	16	20,5	20,5	30,5	77	
□S (mm)	9	9	11	11	14	14	14	17	17	22	22	27	∅45	
J (mm)	42	42	42	42	50	50	50	70	70	102	102	125	125	
nxd1 (mm)	4x6	4x6	4x6	4x6	4x7	4x7	4x7	4x9	4x9	4x12	4x12	4x13,5	4x13	
K _{vs} (m ³ /h)	22,1	47,2	82,3	154,2	242,3	380,2	644,5	978,9	1532,8	2210,2	3231,5	5532,5	10510	
Nm	15	20	25	30	35	40	50	80	100	180	250	600	2000	
Weight (kg)	A	2,6	3,4	4,0	6,1	7,8	10,2	13,8	17,0	23,3	35,0	42,0	115	180
	C	2,6	3,4	4,0	6,1	7,8	10,2	13,8	17,0	23,3	35,0	42,0	115	---

DIMENSIONS (I)

DN	15	20	25	32	40	50	65	80	100	125	150	200	
L (mm) I	115	120	125	130	140	150	170	180	190	325	350	400	
A (mm)	167	167	196	196	244	279	323	323	323	630	554	---	
H (mm)	102	106	114	123	127	133	159	184	207	273	292	---	
H1 (mm)	40	43	59	67	87	92	104	119	144	184	203	262	
ISO 5211	F05	F05	F05	F05	F07	F07	F07	F10	F10	F12	F12	---	
K _{vs} (m ³ /h)	22,1	47,2	82,3	154,2	242,3	380,2	644,5	978,9	1532,8	2210,2	3231,5	5532,5	
Weight (kg)	I	2,6	3,4	4,4	6,8	8,0	10,1	14,5	18,7	27,4	50,2	67,0	144

Data given can be changed without notice.

Edition 01/2026

TORQUE TABLE for 565I

DN		15	20	25	32	40	50	65	80	100	125	150	200
Torque T Nm	1	4	6	10	13	15	19	57	81	98	194	253	435
	1.3	5	8	13	16	19	25	74	106	127	252	329	565
	2	8	12	21	25	30	39	113	163	196	388	506	848
	3	12	18	31	38	45	58	170	244	294	582	759	1324

- 1 for liquid
- 1.3 for air when opened frequently
- 2 for air with an opening frequency of once a week
- 3 for loose media with an opening frequency of once a month

NOTES

When selecting an actuator for a ball valve, please remember to choose an actuator with at least 30% higher torque than the nominal value.
 The valve with the actuator should be checked for functionality before installation in order to verify correct operation.
 The customer may select the actuator independently, taking the above notes into account, but it is recommended to consult the selection with the valve manufacturer.
 The manufacturer is not liable for any damage to the ball valve resulting from an incorrectly selected actuator.

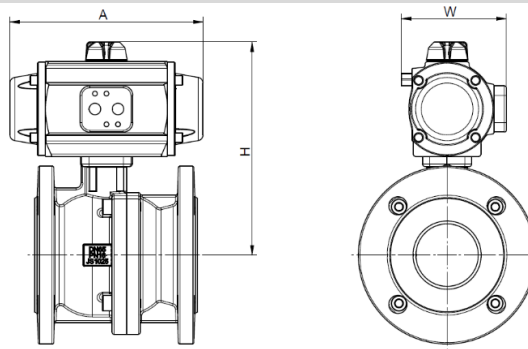
FIG.565
WITH DOUBLE- AND SINGLE-ACTING PNEUMATIC ACTUATOR

DN	15	20	25	32	40	50	65	80	100	125	150	200	
Double-acting	PA00	PA00	PA00	PA00	PA00	PA00	PA05	PA15	PA20	PA25	PA25	P40	
A (mm)	155	155	155	155	155	155	201	265	312	358	358	444	
H (mm)	155,5	158	163	173	188	195	223	264	297	355	372	532	
W (mm)	84	84	84	84	84	84	102	119	127	153	153	226	
Weight (kg)	A	3,2	5,0	5,5	8,0	9,5	12,0	16,5	21,5	29,0	44,5	51,5	133,0
	B	3,2	5,0	5,5	8,0	9,5	12,0	16,5	21,5	29,0	44,5	51,5	133,0
Single-acting	PA05S	PA05S	PA10S	PA10S	PA10S	PA10S	PA20S	PA25S	PA30S	P40S	P40S	PA60S	
A (mm)	201	201	226	226	226	226	312	358	429	598	598	672	
H (mm)	172,5	175	184	194	209	216	251	300	341	452	469	628	
W (mm)	102	102	104	104	104	104	127	153	169	226	226	331	
Weight (kg)	A	5,8	6,5	8,0	10,0	11,5	14,0	20,5	28,5	39,0	71,5	78,5	199
	B	5,8	6,5	8,0	10,0	11,5	14,0	20,5	28,5	39,0	71,5	78,5	199

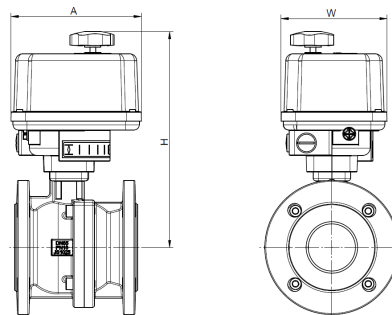
WITH ELECTRIC ACTUATOR PSR-E

DN	15	20	25	32	40	50	65	
PSR-E	PSR-E25	PSR-E25	PSR-E25	PSR-E25	PSR-E25	PSR-E25	PSR-E50	
A (mm)	180	180	180	180	180	180	180	
H (mm)	239,5	242	247	257	272	279	290	
W (mm)	146	146	146	146	146	146	146	
Weight (kg)	A	3,2	4,0	6,7	7,0	10,5	13,0	16,5
	B	3,2	4,0	6,7	7,0	10,5	13,0	16,5

Data given can be changed without notice.

Edition 01/2026

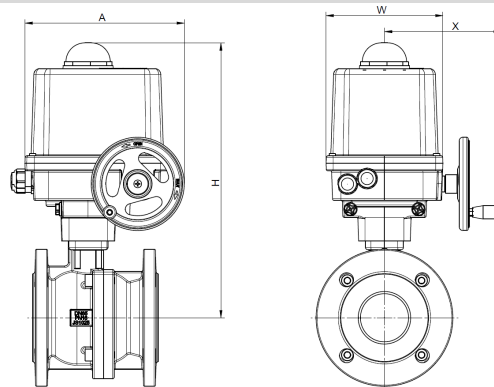
FIG.565
WITH ELECTRIC ACTUATOR PSQ-E, PSQ

DN		80	100	125	150	200
PSQ-E, PSQ		PSQ-E100	PSQ-E150	PSQ203-250Nm	PSQ203-300Nm	PSQ703
A (mm)		206	206	276	276	323
H (mm)		393	418	535	549	665
W (mm)		158	158	185	185	218
X (mm)		172	172	214	214	241
Weight (kg)	A	23,5	27,0	46,5	53,5	143,0
	B	23,5	27,0	46,5	53,5	143,0

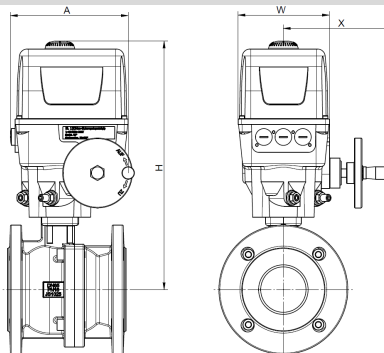
WITH ELECTRIC ACTUATOR ED,EQ

DN	15	20	25	32	40	50	65	80	100	125	150	
ED,EQ	ED25	ED25	ED25	ED25	ED25	ED25/ EQ40	ED50/ EQ60	EQ100	EQ150	EQ300	EQ300	
A (mm)	166	166	166	166	166	166/ 169	166/ 169	169	169	169	169	
H (mm)	243,5	246	251	261	276	283/ 339	294/ 350	371	396	426	443	
W (mm)	131	131	131	131	131	131	131	131	131	131	131	
X (mm)	-	-	-	-	-	-/ 155	-/ 155	155	155	155	155	
Weight (kg)	A	3,0	4,5	8,2	10,2	12,0	14,5/ 18,0	18,0/ 21,5	25,0	31,0	50,0	50,0
	B	3,0	4,5	8,2	10,2	12,0	14,5/ 18,0	18,0/ 21,5	25,0	31,0	50,0	57,0

Data given can be changed without notice.

Edition 01/2026

FIG.565

WITH ELECTRIC ACTUATOR SQ

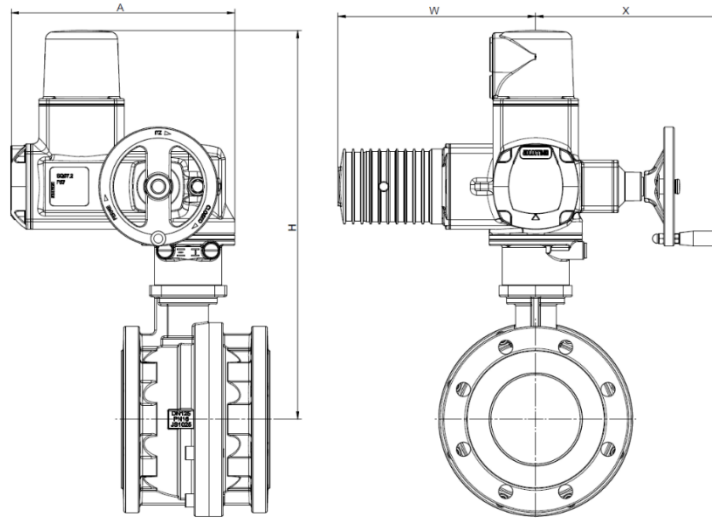

DN		80	100	125	150	200
SQ		SQ 5.2	SQ 5.2	SQ 7.2	SQ 7.2	SQ 12.2
A (mm)		288	288	288	288	313
H (mm)		469	494	524	541	645
W (mm)		265	265	265	265	265
X (mm)		249	249	249	249	249
Weight (kg)	A	39,0	45,0	57,0	64,0	150,0
	B	39,0	45,0	57,0	64,0	150,0

PRESSURE-TEMPERATURE RATINGS

	PN	-30°C÷-10°C	-10°C÷100°C	150°C	200°C	220°C
EN-GJL-250	10	bar	10	9,0	---	---
EN-GJL-250	16		16	14,4	---	---
EN-GJS-400-18LT	16		16	15,5	---	---
X5CrNiMo17-12-2	16		16	14,5	10,0	3,5

Data given can be changed without notice.

Edition 01/2026

FIG.565
FLANGE DIMENSIONS ACC. PN-EN 1092-1/-2

DN		15	20	25	32	40	50	65	80	100	125	150	200	250
PN 10	D (mm)	95	105	115	140	150	165	185	200	220	250	285	340	-
	K (mm)	65	75	85	100	110	125	145	160	180	210	240	295	-
	nxd (mm)	4x14	4x14	4x14	4x19	4x19	4x19	4x19	8x19	8x19	8x19	8x23	8x23	-
PN16	D (mm)	95	105	115	140	150	165	185	200	220	250	285	340	405
	K (mm)	65	75	85	100	110	125	145	160	180	210	240	295	355
	nxd (mm)	4x14	4x14	4x14	4x19	4x19	4x19	4x19	8x19	8x19	8x19	8x23	12x23	12x26

TYPE

Figure	Body material	Nominal diameter	Nominal pressure	Type
565	A Grey cast iron EN-GJL-250	15-200 mm	C 16 bar	09 ball AISI 304; ball seat PTFE; stem- stainless steel
565	C Nodular cast iron EN-GJS-400-18LT	15-200 mm	C 16 bar	09 ball AISI 304; ball seat PTFE; stem- stainless steel
565	I Stainless steel X5CrNiMo17-12-2	15-200 mm	C 16 bar	09 ball AISI 304; ball seat PTFE; stem- acid-resistant steel

Data given can be changed without notice.

Edition 01/2026

FIG.565
ORDERING

Figure	Body material	Nominal diameter	Nominal pressure	Type
565	A Grey cast iron EN-GJL-250	15-250 mm	C 16 bar	09 ball AISI 304; ball seat PTFE; stem- stainless steel

Order example acc. index
565 A 050 C 09

Ball valve, ends flanged, form straight

Grey cast iron EN-GJL-250

Nominal diameter (mm)

Nominal pressure PN 16

Ball AISI 304; ball seat PTFE; stem- stainless steel

565
A
050
C
09

Data given can be changed without notice.

Edition 01/2026

 ZETKAMA Sp. z o.o.
 Ul. 3 Maja 12
 PL 57-410 Ścinawka Średnia

 E-mail export@zetskama.com.pl
www.zetskama.com